

Features

- (1) Compact and High current density On-board type:
Rated current 20A with DC48V input line.
- (2) Suitable size for the PCB-mounting:
46(W) x 12.7(H) x 46(D)mm.
- (3) Matches best for use in conjunction with
Densei-Lambda's power modules for telecommunication
equipment: Meets EMI-standardized requirements with PAF
and/or PAH series used together.
- (4) Patent and design registration pending.

Safety standard

Conforms to UL1950, CSA950 and EN60950

Specifications

Item	Model	PAN4820
1 Rated voltage (DC)		DC76V
2 Rated current (DC) *		20A
3 Test voltage		Terminal - FG: DC1500V, 1min. Terminal - Terminal: DC100V, 1min.
4 Isolation resistance		Terminal - Case: DC500V, 100Mohm
5 Cooling		Convection cooling or forced air cooling
6 Operating Temperature		-40 ~ +85°C (Convection Cooling) -40 ~ +100°C (1m/s ² Forced Air Cooling)
7 Operating Humidity		30 ~ 95% RH (No Dewdrop)
8 Storage Temperature		-40 ~ +100°C
9 Storage Humidity		10 ~ 95% RH (No Dewdrop)
10 Vibration		10 ~ 55Hz Sweep for 1 min Amplitude 0.825mm(max 49.0m/s ²), X, Y, Z, 1 Hour each
11 Weight (typ.)		45g

NOTE

* Convection cooling Ta≤75°C Forced air cooling (1m/sec), Ta≤90°C
Refer to derating curve on the right

Outline drawings

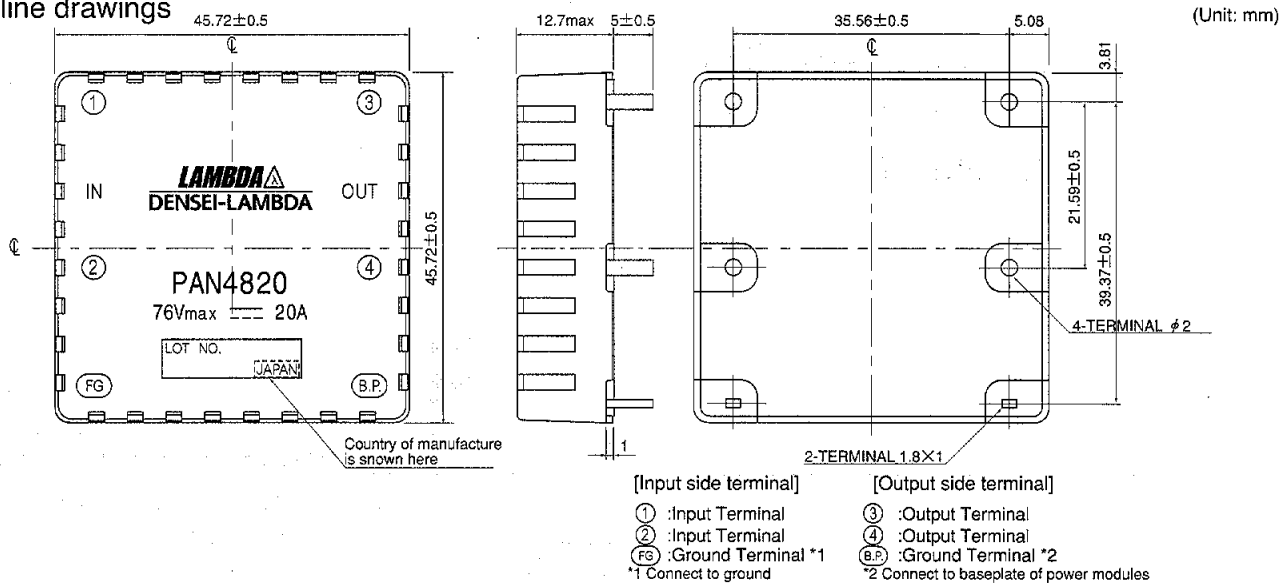

Derating

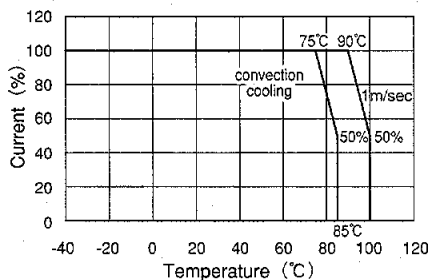

Attenuation characteristics

● CLASS-A Application
PAN4820+PAF500F

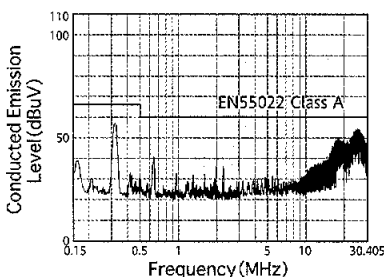

● CLASS-B Application
PAN4820+adding external components
(Capacitor: Net 3)+PAF500F

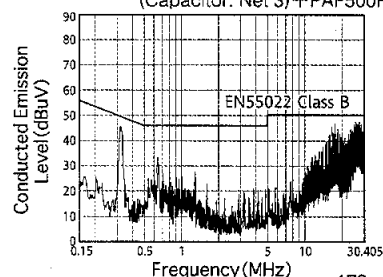

■ Connection-1. [Basic Connection]

In input/output of power modules, please connect resistor/capacitor properly as we recommend in our instruction manuals for power modules. Fuse is not included in the unit, so please install appropriate fuse in input side as guided in our instruction manual of power modules.

■ Conform to EN55011/55022, VCCI Class A

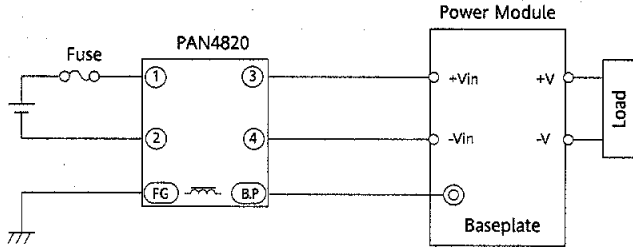

● Class-A Application
PAN4820+PAF500F

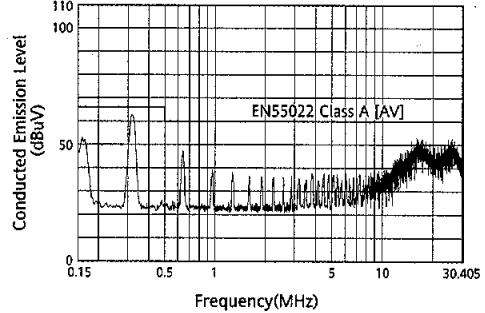

■ Conform to EN55011/55022, VCCI Class B

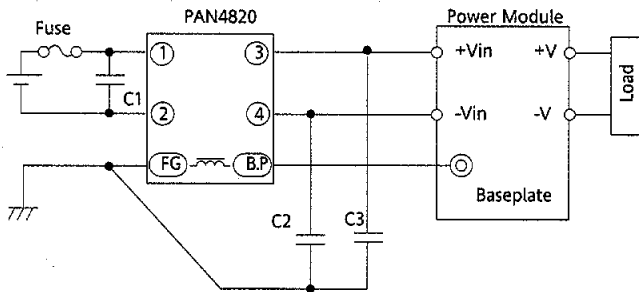

● Class-B Application

PAN4820+PAF500F+adding external components(Capacitor: Net 3)

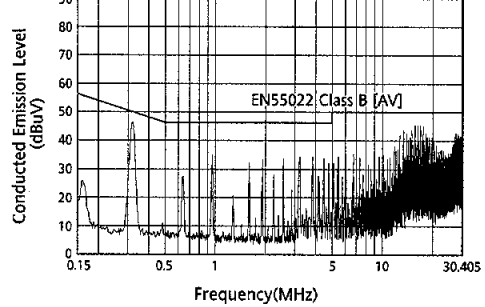

Recommended Values C1: 22 μ F (Ceramic Capacitor)
C2,3: 0.47 μ F(Film or Ceramic Capacitor)

Remark) Above connection conforms to each standard in our test condition by combining PAN series with our power modules (PAF500F48 series or PAH200H48 series). In some cases concerned with below mentioned or the like, PAN series will not conform to the standards. So, please be sure to measure EMI values (noise terminal voltage, noise electrolysis intensity) with actual equipment.

- Quantity of power modules connected / model structure / load condition
- Wiring method of input and output
- Surrounding circuits

Noise Filter

■ Connection-2. [Other method of connection] (With baseplate and -V of power module grounded)

This noise filter will provide you with the best performance with the condition of baseplate and output (+V or -V) non-grounded. If baseplate and output (+V or -V) need to be grounded, connect C1, C2, and C3 shown in the above.

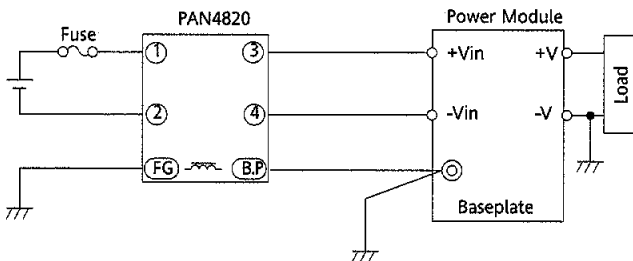

● PAN4820+PAF500F

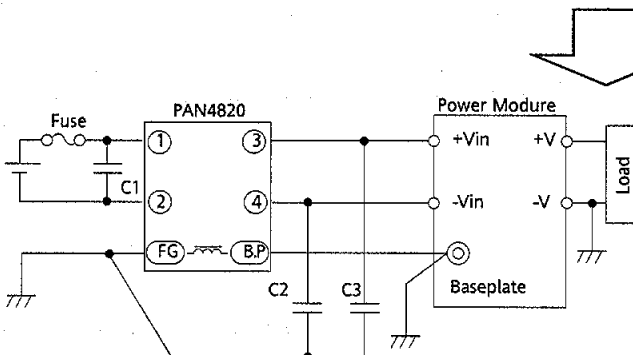
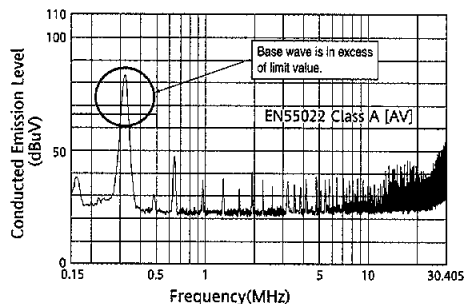

● PAN4820+PAF500Fadding external components(Capacitor: Net 3)

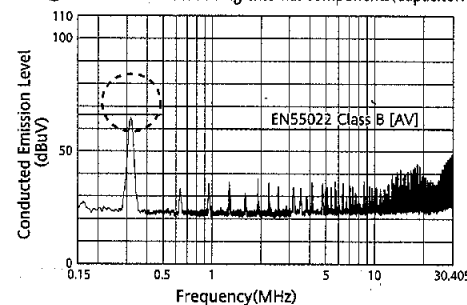

Recommended Values C1: 22 μ F (Ceramic Capacitor)
C2,3: 0.47 μ F(Film or Ceramic Capacitor)