

Features

- (1) For equipment designed to meet EMI regulations such as VCCI, CISPR, FCC, VDE, etc.
- (2) Attenuation effect against high voltage pulse noise
- (3) Attenuates conductive emission from power supply
- (4) Leakage current: 1mA max. (250V, 60Hz)
- (5) High shielded effect

Safety standard

- UL1283, CSA Std. C22. 2 No. 8
- VDE0565 Teil. 3
- (VDE0565 will transfer to EN133200 on and after July 23, 2003.)

Specifications

Item	Model	MBS-1205-22	MBS-1210-22	MBS-1215-22	MBS-1220-22	MBS-1230-22
1	Rated voltage (AC, DC)	250V				
2	Rated current (AC, DC)	5A (Note 1)	10A (Note 1)	15A (Note 2)	20A (Note 2)	30A (Note 2)
3	Test voltage (terminal to case, AC 1 minute)	2500V				
4	Isolation resistance (terminal to case, 500VDC)	100MΩ min.				
5	Leakage current	125V, 60Hz		0.5mA max.		
		250V, 60Hz		1mA max.		
6	DC resistance	0.15Ω max.	0.05Ω max.	0.03Ω max.	0.02Ω max.	0.01Ω max.
7	Temperature rise	30°C max.			35°C max.	
8	Operating temperature range	-25 ~ +85°C				
9	Weight (typ)	310g	310g	550g	550g	1,100g

(Note 1) : Value at Ta ≤ 55°C. Refer to the derating curve (A) shown below at Ta > 55°C.
 (Note 2) : Value at Ta ≤ 50°C. Refer to the derating curve (B) shown below at Ta > 50°C.

Circuit

MBS-1205, -1210, -1215, -1220

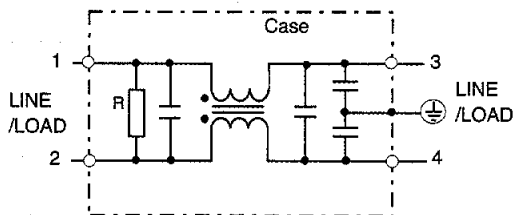

R: Breeder resistance

MBS-1230

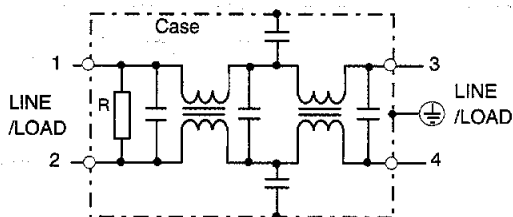

R: Breeder resistance

Derating

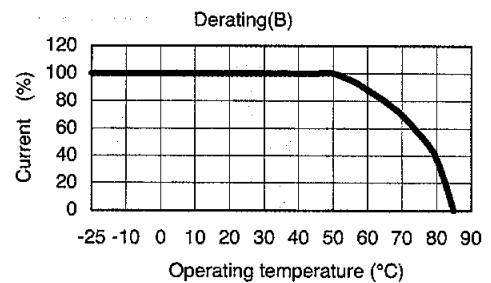
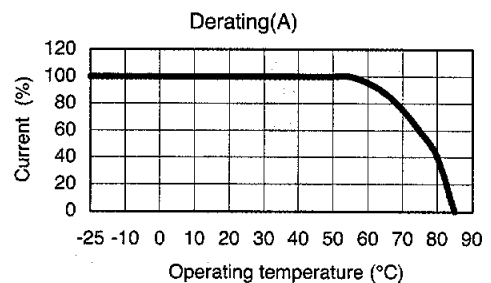

- Request customer specification for further details of specifications, outline, characteristics, etc. Read the instruction manual before usage.
- Contact us about delivery before ordering.

MBS-SERIES

- MBS-1205-22
- MBS-1210-22

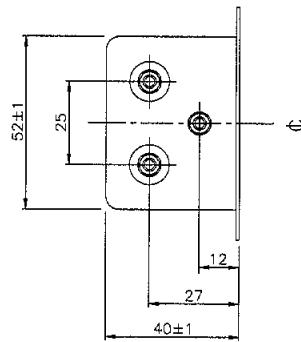
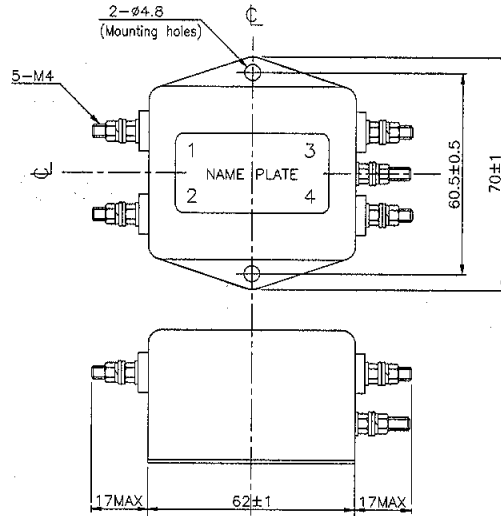

Case: Metal
(Unit: mm)

- MBS-1215-22
- MBS-1220-22

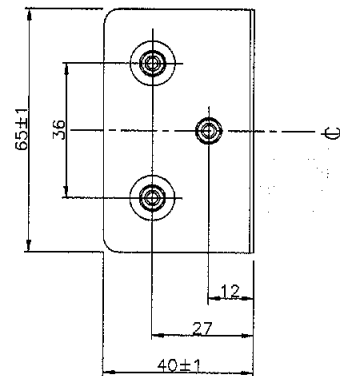
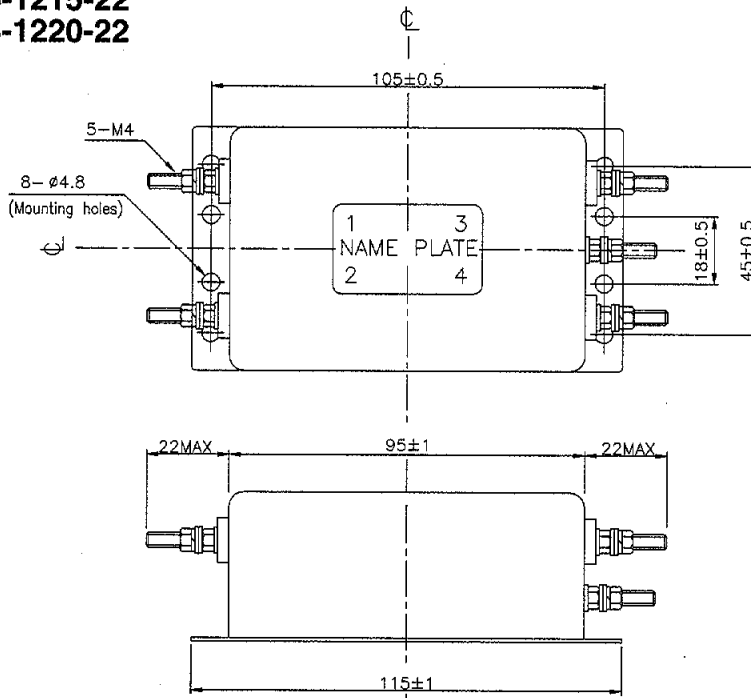

Case: Metal
(Unit: mm)

- MBS-1230-22

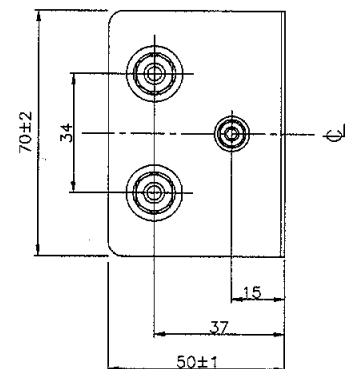
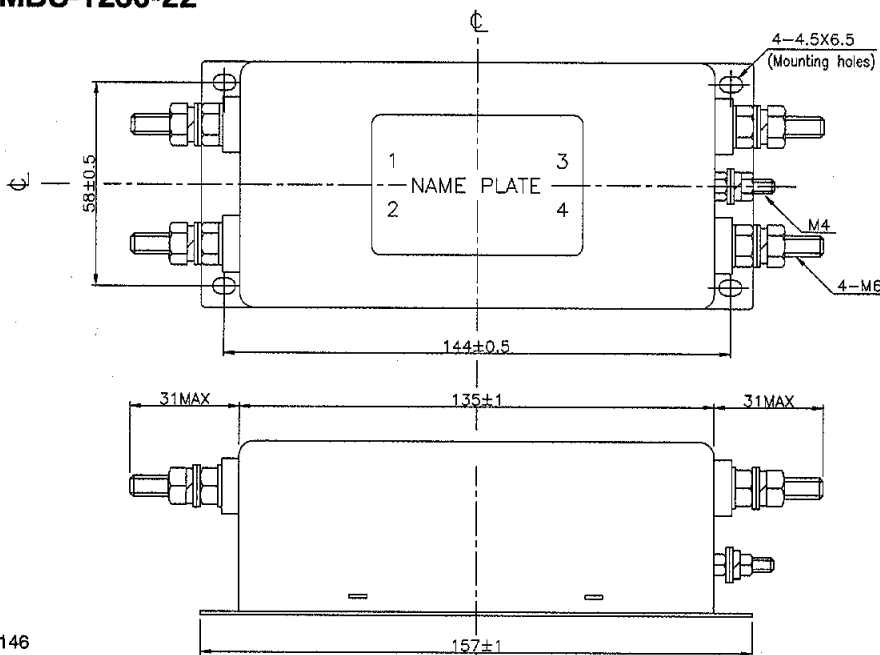

Case: Metal
(Unit: mm)

Noise Filter

CHARACTERISTICS

■ Typical Insertion Loss Symmetrical
 ----- Asymmetrical

MBS-1205

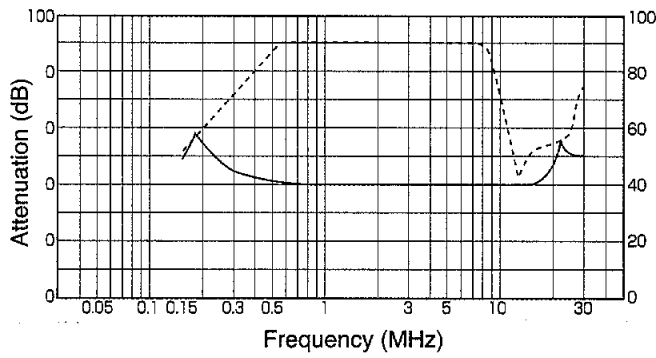

MBS-1210

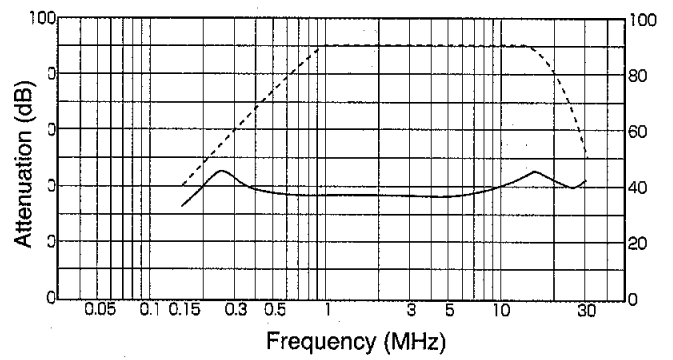

MBS-1215

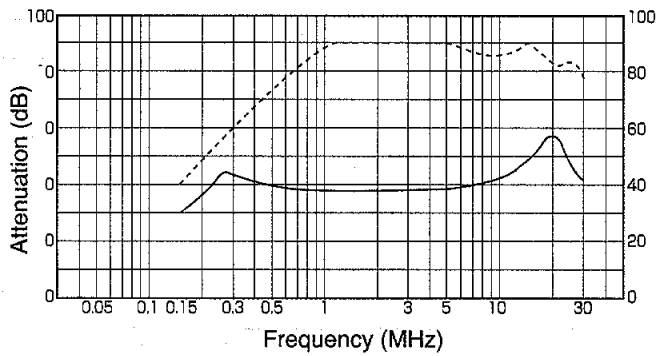

MBS-1220

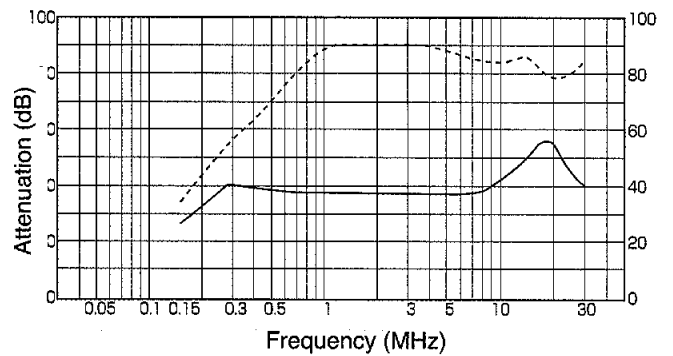

MBS-1230

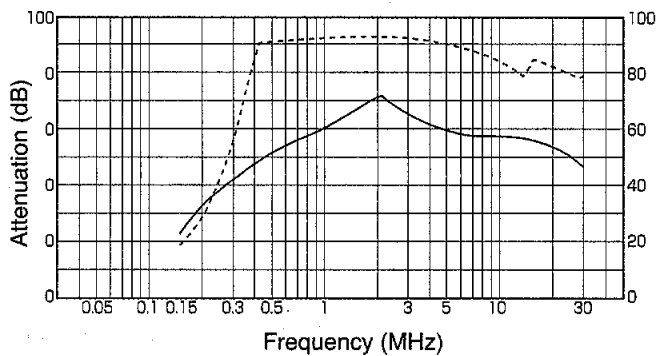

Noise Filter