



■ Features

- (1) For equipment designed to conform EMI regulations such as VCCI, CISPR, FCC, VDE etc.
- (2) Attenuation effect against high voltage pulse noise.
- (3) Attenuates conductive emission from power supply.
- (4) Leakage current: 1mA max. (250V, 60Hz).
- (5) High shielded effect.
- (6) Compact and light weight.

■ Safety standard

-  UL1283,  CSA Std. C22. 2 No. 8
-  VDE0565 Teil. 3

■ Specifications

Item	Model	MAF-1206-33	MAF-1210-33	MAF-1215-33	MAF-1220-33
1	Rated voltage (AC, DC)	250V			
2	Rated current (AC, DC) (Note)	6A	10A	15A	20A
3	Test voltage (terminal to case, AC 1 minute)	2500V			
4	Isolation resistance (terminal to case, 500VDC)	100MΩ min.			
5	Leakage current	0.5mA max.			
		1mA max.			
6	DC resistance	0.10Ω max.	0.05Ω max.	0.03Ω max.	0.02Ω max.
7	Temperature rise	30°C max.			
8	Operating temperature range	-25 ~ +85°C			
9	Weight (Typ)	290g			

(Note) : Value at Ta ≤ 55°C. Refer to the derating curve shown below at Ta > 55°C.

■ Circuit

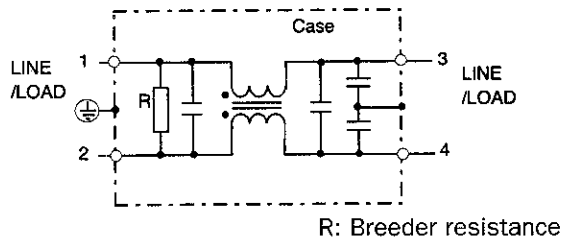

■ Derating

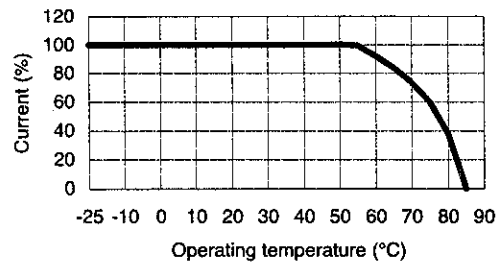

■ Outline drawings

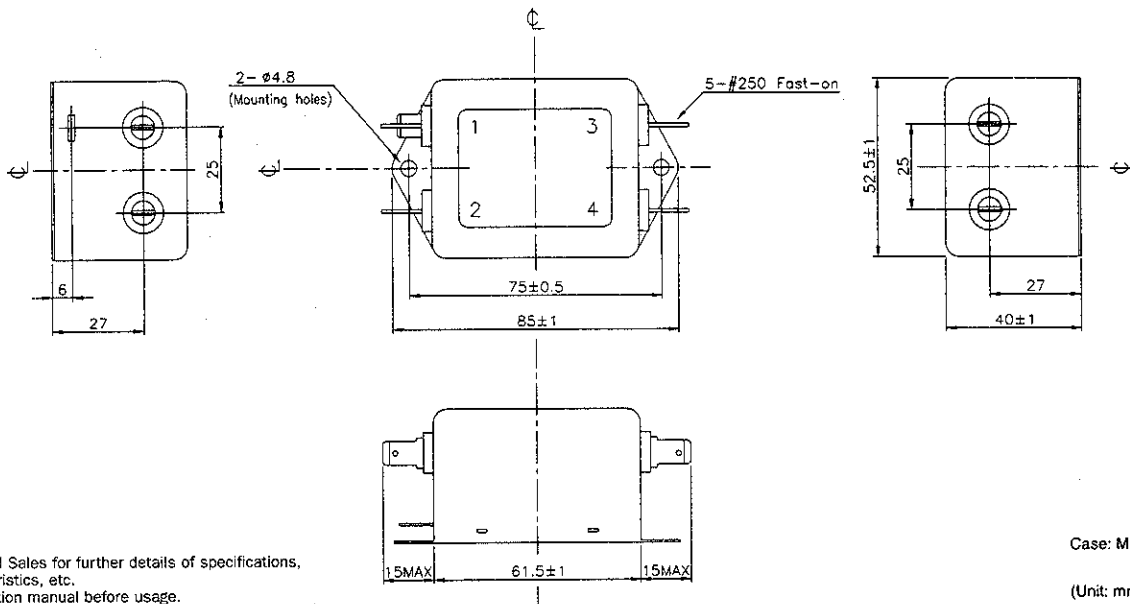

- Contact Technical Sales for further details of specifications, outline, characteristics, etc.
- Read the instruction manual before usage.
- Contact us about delivery before ordering.

CHARACTERISTICS

■ Typical Insertion Loss Symmetrical
 — Asymmetrical

MAF-1206

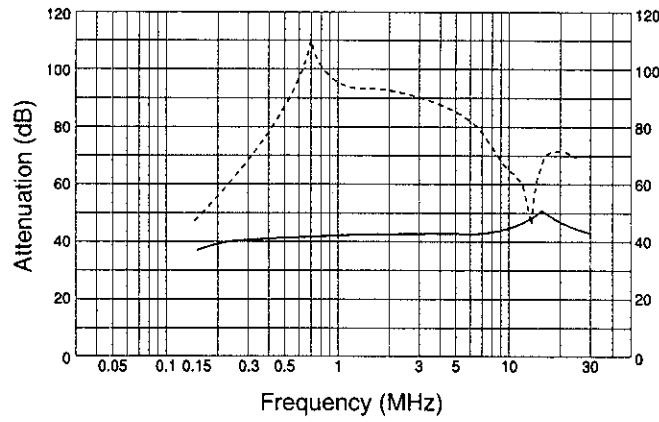

MAF-1210

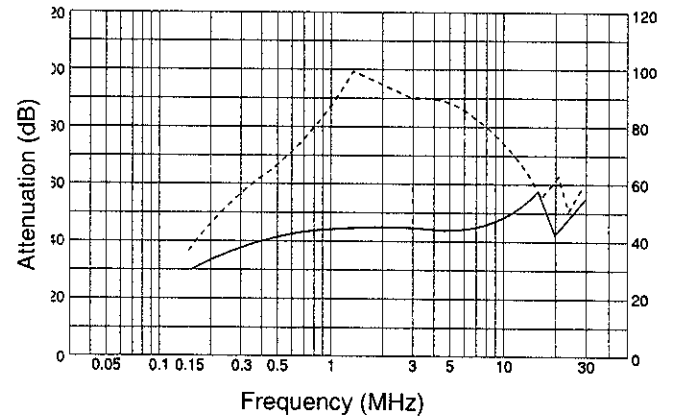

MAF-1215

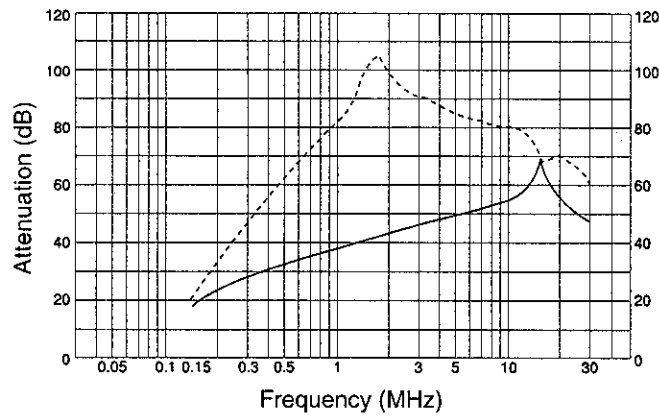

MAF-1220

