

## Advantages of AC-DC “Brick” Power Modules

Compact DC-DC converters have made their way into millions of electronic products and systems. The vast majority of these depend upon an AC-DC power supply (metal box or chassis-mount) to convert the AC into a DC voltage from which the converters can operate. In addition, regulations have mandated that these power supplies include Power Factor & Harmonic Correction (PFHC) to maximize the available power from the power grid. Add to this the need to be as small as possible and to operate with in harsh ambient temperatures and the designer is faced with a problem that is not easily solved.

### Traditional Distributed Power Solutions

Traditional designs that employ distributed power architecture place DC-DC converters on PC boards very close to the point-of-load to maximize system speeds and efficiencies. To power the DC-DC converters, the required AC-DC power supply with PFHC is typically mounted somewhere in the system’s enclosure, external to the main pc-board (Figure 1).

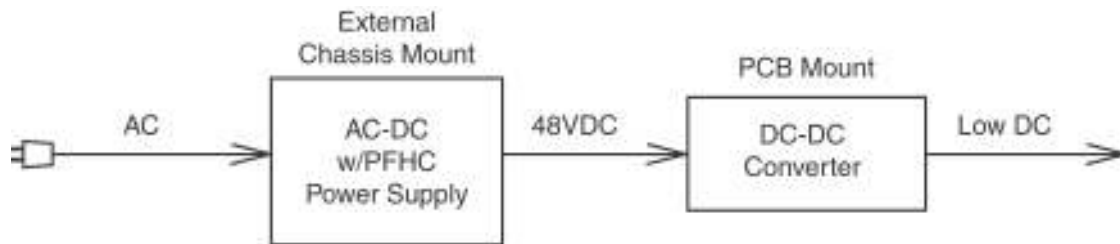

FIGURE 1

This technique is quite reasonable for most applications. However, when it comes to equipment that must be mounted outdoors and occupy the smallest possible volume, there are now improved power products available.

### Improved Power Distribution Methods (2 Brick Solution)

Typical medium power (400-700 watts) PCB mounted DC-DC converters are packaged in “full brick” sizes (e.g., 2.4” W x 4.6” L x 0.5” H). A number of major manufacturers of DC-DC converters have seen the need for, and are now providing AC input PFHC front ends in brick-formats that are PCB mountable near to the DC-DC converter(s). This has the advantage of placing all the power components on the same pc-board thus reducing the end products size and eliminating the power interconnect wires (Figure 2).

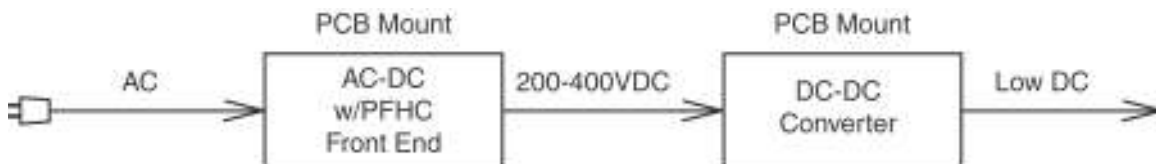

FIGURE 2

These AC-DC w/PFHC front-end bricks require some external components (capacitors, resistors, etc.), but the space required for these items is small in comparison to the elimination of the external “metal boxed AC front end”. And, these external components can be robotically inserted during the production of the pc-board. An added benefit of utilizing these brick packages is that they can be cooled by means of heat sinks or cold plates (e.g., mounting the brick bases against the system’s cooler metal enclosure).

### AC-DC Power Modules (1 Brick Solution)

TDK-Lambda has continued to develop smaller and better power solutions. In fact, in recent times the AC/PFHC brick mentioned above has been merged with a DC-DC converter to form the ultimate power solution; an AC/PFHC/DC integrated brick. These 2-in-1 devices (single brick solution) accept wide range 85 to 265 VAC inputs, corrects the power factor, and provide the DC output(s) to the system. All this is accomplished within the same size constraints of a single “full brick” package measuring only 2.4” W x 4.6” L x 0.5” H, thus providing a 50% board space savings (Figure 3).

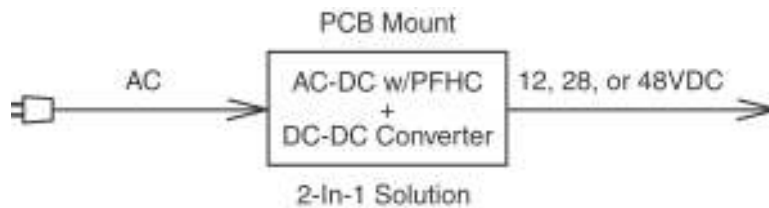

FIGURE 3

These integrated 2-in-1 pcb-mounted single power bricks are ideal for Distributed Power Architectures where POL (Point of Load) Converters are needed. Since the 2-in-1 Power Bricks provide the conversion from AC to DC (with PFHC) along with the needed isolation, and the Intermediate Bus Voltage, the use of multiple low-cost, non-isolated POL converters becomes quite practical (Figure 4).

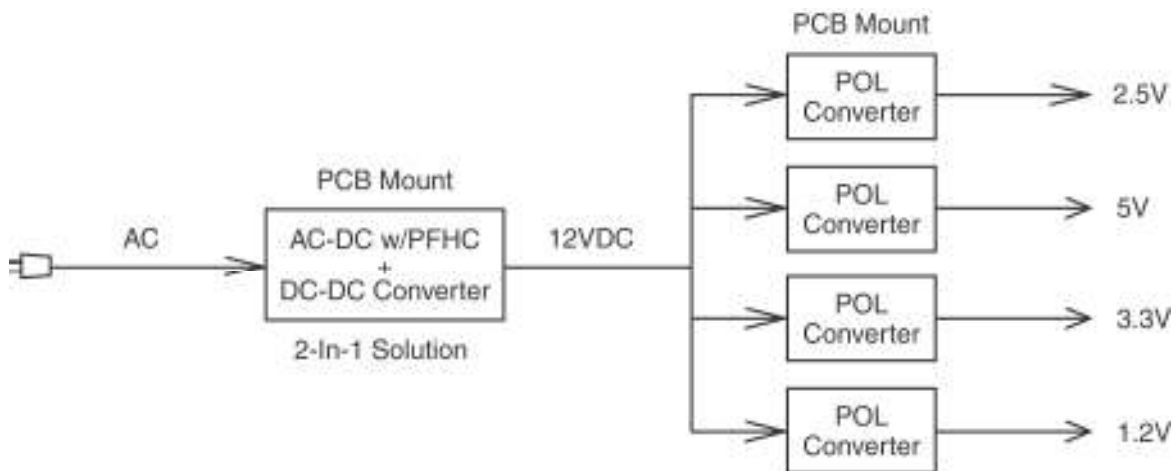

FIGURE 4

In order to increase power densities, special permalloy cores have been developed and employed in the transformers and inductors. New substrates and innovative transformer winding techniques have facilitated component height compressions and improved thermal management. And, of course, advances in integrated and hybrid circuits have contributed greatly to this next generation of power products.

### **Applications of “Single Brick” AC-DC Power Modules**

These new “single brick” AC-DC power bricks are ideal for outdoor and indoor applications including:

- Custom Power Supplies
- PCB Mounted Bulk Power for Multiple DC-DC or POL Converters
- Large LED & Liquid Crystal Displays
- Traffic Information, Control, & Signaling Equipment
- Toll Devices
- Pico & Cell Phone Repeaters
- WiFi, Broadcast & Telecom Sub-Stations
- Underwater Surveying Devices
- Automatic Pass-Reading-Devices for FastTrac Car Lanes
- Oil Pumping & Pipeline Monitoring Devices
- Security Systems

### **Specifications for “Single Brick” AC-DC Power Modules from TDK-Lambda**

TDK-Lambda designed and developed a new range of integrated “single-brick” AC-DC power bricks, their PFE Series. These pcb-mount devices are so innovative, they have seven patents pending.

Some of the salient features of TDK-Lambda’s single-brick AC-DC **PFE Series** power modules include:

- Low Profile, Single-Brick Footprint
- High Power Density (up to 129W/in<sup>3</sup>) & Efficiency (up to 90%)
- Regulated and Isolated DC Outputs: 12V, 28V, 48V and 51V
- Output Power Ratings: 300W, 500W, 700W and 1000W
- +/-20% Output Voltage Adjustment Range
- Over Voltage/Current/Temperature Protection
- Approved to UL/CSA/EN60950-1, CE Marked, & RoHS Compliant
- Heatsinks & Evaluation Boards/Kits Available
- Adaptable to cold-plate cooling without a fan
- Wide Operating Temperature Range: -40°C up to +100°C (at base)
- Operates from Universal 85 to 265VAC, 47-63Hz Input (440Hz operation possible)
- Power Factor & Harmonic Correction Meets EN61000-3-2
- Active Current Sharing for Paralleling up to 6 modules is available (see PFE500F & PFE1000F series)



Photo of Lambda's PFE 700-watt AC-DC Power Module



PFE Series Power Module mounted on Evaluation Board with heatsink and external components

For detailed information about the **PFE Series** power modules and the available accessories including evaluation boards, heatsinks, pc board layouts, etc., please visit this website: <http://www.us.tdk-lambda.com/lp/products/pfe-series.htm>